

EFV Series

Adjustable Excess Flow Valve

23

Key Features

Controls excessive flows.

Features

- Controlled Bleed, Resets Automatically
- Field Adjustable
- Positive Shut-off
- Function: Restricts or Shuts Off Flow
- Output: Switch Contact Optional
- Materials: 316SS or Brass Body

Applications

- Fitting Failure
- Regulator failure
- Hydraulic control
- Gas Analyzers
- Toxic Gas and Liquid Releases



Operation

Flow enters the unit and makes a right angle to the outlet port across the nose of a magnetic piston. The piston is held in place by attraction to an adjusting screw magnet. A pressure differential is created by flow across the piston. When the differential is great enough, the piston slides to a seat at the outlet port. The flow rate at which the piston actuates can be changed externally by turning the adjusting screw, thereby changing the piston's relationship with the flow stream. In this auto reset model after actuation, the piston rests on a metal to metal seat which allows a controlled bleed. To reset the unit, pressure must be equalized on both sides of the piston. If the source is turned off, either upstream or downstream, the bleed will equalize the pressure and the valve will automatically reopen by magnetic repulsion from the fixed magnet located in the valve body.

For positive shut-off an elastomer is used on the nose of the piston. When it comes to rest on the seat it provides a bubble tight closure. To reopen the valve there are two options.

1. The upstream pipeline must be led to atmosphere if the line downstream is at atmosphere.
 2. A by-pass line with an on/off valve must be installed to port the upstream pressure to the down-stream pipeline to equalize the pressure.
- Our MRS series is available with the by-pass system as an integral part of the unit.

- Actuation points for air at 68°F and 14.7 PSIA.

Correction must be made for other fluids, line pressure and temperatures. Please consult your representative or the factory.

Temperature Operating Range

- 0° to 220°F (-17° to 104°C)
- For other temperature ranges consult factory.

Calibration Range

Model	Adjustable Range Air SLPM (SCFM)	Adjustable Range Water LPM (GPM)	PORT FNPT
EFV-125	0.5 to 155.7 (0.018 to 5.5)	0.015 to 4.5 (0.004 to 1.2)	1/8"
EFV-250	4 to 1132 (0.14 to 40)	0.100 to 15.1 (0.026 to 4.0)	1/4"
EFV-375	85 to 1840 (3.0 to 65)	0.380 to 15.1 (0.100 to 4.0)	3/8"
EFV-500	142 to 2123 (5.0 to 75)	1.90 to 37.8 (0.50 to 10.0)	1/2"
EFV-750	425 to 3681 (15.0 to 130)	3.80 to 75.7 (1.0 to 20.0)	3/4"

Pressure Loss

Model	Air SLPM (SCFM)	Water LPM (GPM)	ΔP to Atmosphere BARD (PSID)
EFV-125	0.50 (0.018)	0.015 (0.004)	0.08 (1.2)
	75 (2.63)	2.65 (0.70)	0.11 (1.6)
	155 (5.5)	4.50 (1.20)	0.21 (3.0)
EFV-250	4 (0.14)	0.1 (0.26)	0.21 (3.0)
	500 (17.50)	5.0 (1.32)	0.41 (6.0)
	1132 (39.62)	15.1 (3.99)	0.83 (12.0)
EFV-375	85 (2.98)	0.38 (0.10)	0.10 (1.5)
	900 (31.50)	10.0 (2.64)	0.28 (4.0)
	1840 (64.40)	15.1 (3.99)	0.83 (12.0)
EFV-500	142 (4.97)	1.9 (0.50)	0.07 (1.0)
	1000 (35.00)	25.0 (6.60)	0.28 (4.0)
	2123 (74.31)	37.8 (9.98)	0.48 (7.0)
EFV-750	425 (14.88)	3.8 (1.00)	0.14 (2.0)
	1800 (63.00)	4.7 (1.24)	0.21 (3.0)
	3681 (128.84)	75.7 (19.98)	0.34 (5.0)

CE

EFV Series

Adjustable Excess Flow Valve

ES - Option

Switch Data	SPST UL File #E471070	LEADS
Maximum Switching Voltage		
DC (V)	250	
AC (V)	265	
Contact Rating		leads 18 in. min. from body 22 AWG, TFE insulation
DC (W)	50	
DC (VA)	50	
Maximum Switching Current (A)		
DC (A)	1.5	
AC (A)	1.1	

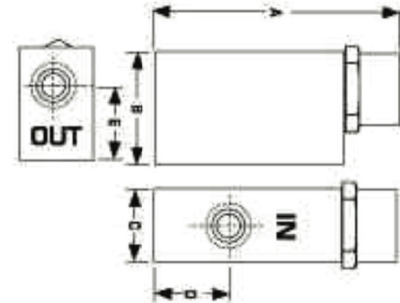

Body Material	Max Working Pressure PSIG (barg)	Wetted Parts	Seals
Brass	1500 (103.42)	Brass, Epoxy, Delrin (Brass Piston in 125 Unit)	Viton ®
316SS	3000 (206.84)	316SS, Epoxy	Viton ®

Installation

We suggest the unit be calibrated in the attitude in which it will be installed. An actuation point approximately 3 or 4 times normal flow rate should be chosen to avoid the valve actuating from initial pressurization of the system and normal surges. If flow is kept constant, an actuation point 10% above the normal rate may be used.

Dimensions

Model	Weight	A	B	C	D	E
EFV-125	0.25 (113.4)	2.5 (64)	1 (25)	0.75 (19)	0.7 (17)	0.63 (16)
EFV-250	0.50 (226.8)	3.3 (84)	1.50 (38)	1 (25)	1 (25)	1 (25)
EFV-375	0.50 (226.8)	3.3 (84)	1.50 (38)	1 (25)	1 (25)	1 (25)
EFV-500	1 (453.6)	4.0 (102)	2 (50)	1.25 (31)	1.25 (31)	1.38 (35)
EFV-750	1.50 (680.4)	4.9 (124)	2.25 (57)	1.25 (31)	1.25 (31)	1.63 (41)

How to Order

Sales@ChemTec.com | 800.222.2177

Model	Size	Materials	Positive Shut-Off	Options
EFV	125 250 375 500 750	B Brass S 316SS (Other Material available on request)	PSO (Blank for Controlled Bleed Model)	ES Reed Switch (Not available on 125 models) O2 Oxygen Cleaned KZ FFKM Perfluoroelastomer EPR EPR Seals FP Factory Presetting (State flow rate, medium and line pressure) Required W/ES Option ESFP Normally Open Reed Switch Option Requires Factory Presetting

*Consult Factory | Viton® - E.I. Dupont & Co | Teflon® - E.I. Dupont & Co | Kalrez® - E.I. Dupont & Co
All dimensions are subject to change for quality improvement. Not responsible for printing errors.

EFV MRS Series

Manual Reset Adjustable Excess Flow Valve

25

Key Features

Controls excessive flows.

Features

- Field Adjustable
- Manual Reset
- Materials: 316SS
- Detects Excess Flows
- Function: Shuts Off Flow
- Output: Switch Contact (Optional)

Applications

- Plant Lines
- Regulator Failure
- Fitting Failure
- Toxic Gases & Liquids
- Gas Distribution Systems
- Gas Analyzers
- Loss Controls



Operation

Flow enters the unit and makes a right angle to the outlet port across the nose of a magnetic piston. The piston is held in place by attraction to an adjusting screw magnet. A pressure differential is created by flow across the piston. When the differential is great enough, the piston slides to a seat at the outlet port. The flow rate at which the piston actuates can be changed by turning the adjusting screw, thereby changing the piston's relationship with the flow stream. The piston makes a bubble tight seal when it comes in contact with the seat. To reopen the unit, turn the balancing valve handle on the side. This ports the upstream pipeline to the downstream pipeline. When the pressure is equalized on each side of the piston, it will reset. The unit is returned to normal operation by closing the balancing valve.

- Actuation points for air at 68° F and 14.7 PSIA.

Corrections must be used for other gases, line pressure and temperatures.* Please consult your representative or the factory.

Temperature Operating Range

- AMBIENT: 0° to 125°F (-18° to 52° C)
- MEDIA: 0° to 180°F (-18° to 82° C)

Calibration Range

Model	Adjustable Range Air SLPM (SCFM)	Adjustable Range Water LPM (GPM)	PORT FNPT
EFV-125	0.5 to 155.7 (0.018 to 5.5)	0.015 to 4.5 (0.004 to 1.2)	1/8"
EFV-250	4 to 1132 (0.14 to 40)	0.100 to 15.1 (0.026 to 4.0)	1/4"
EFV-375	85 to 1840 (3.0 to 65)	0.380 to 15.1 (0.100 to 4.0)	3/8"
EFV-500	142 to 2123 (5.0 to 75)	1.90 to 37.8 (0.50 to 10.0)	1/2"
EFV-750	425 to 3681 (15.0 to 130)	3.80 to 75.7 (1.0 to 20.0)	3/4"

Pressure Loss

Model	Air SLPM (SCFM)	Water LPM (GPM)	ΔP to Atmosphere BARD (PSID)
EFV-125	0.50 (0.018)	0.015 (0.004)	0.08 (1.2)
	75 (2.63)	2.65 (0.70)	0.11 (1.6)
	155 (5.5)	4.50 (1.20)	0.21 (3.0)
EFV-250	4 (0.14)	0.1 (0.26)	0.21 (3.0)
	500 (17.50)	5.0 (1.32)	0.41 (6.0)
	1132 (39.62)	15.1 (3.99)	0.83 (12.0)
EFV-375	85 (2.98)	0.38 (0.10)	0.10 (1.5)
	900 (31.50)	10.0 (2.64)	0.28 (4.0)
	1840 (64.40)	15.1 (3.99)	0.83 (12.0)
EFV-500	142 (4.97)	1.9 (0.50)	0.07 (1.0)
	1000 (35.00)	25.0 (6.60)	0.28 (4.0)
	2123 (74.31)	37.8 (9.98)	0.48 (7.0)
EFV-750	425 (14.88)	3.8 (1.00)	0.14 (2.0)
	1800 (63.00)	4.7 (1.24)	0.21 (3.0)
	3681 (128.84)	75.7 (19.98)	0.34 (5.0)

CE

EFV MRS Series

Manual Reset Adjustable Excess Flow Valve

ES - Options		
Switch Data	SPST UL File #E471070	LEADS
Maximum Switching Voltage		
DC (V)	250	
AC (V)	265	
Contact Rating		leads 18 in. min. from body 22 AWG, TFE insulation
DC (W)	50	
DC (VA)	50	
Maximum Switching Current (A)		
DC (A)	1.5	
AC (A)	1.1	

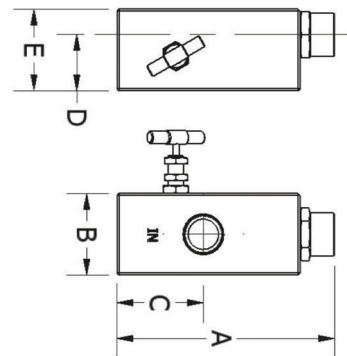

Body Material	Max Working Pressure PSIG (barg)	Wetted Parts	Seals
Brass	1500 (103.42)	Brass, Epoxy, Delrin (Brass Piston in 125 Unit)	Viton®
316SS	3000 (206.84)	316SS, Epoxy	Viton®

Installation

We suggest the unit be calibrated in the attitude in which it will be installed. An actuation point approximately 3 or 4 times the normal Maximum flow rate at the lowest line pressure should be chosen to avoid the valve actuating from initial pressurization of the system and normal surges. If flow is kept constant, an actuation point 10% above the normal rate may be used.

Dimensions								
Model	316SS Weight (lbs/gm)	Brass Weight (lbs/gm)	A	B 316SS	B Brass	C	D	E
EFV-125	1.5 (680)	1.6 (726)	2.72 (69)	1.5 (38)	1.5 (38)	0.95 (24)	1.12 (28)	1.62 (41)
EFV-250	3.5 (1588)	3.3 (1497)	3.71 (95)	2 (50)	1.75 (45)	1.5 (38)	1.38 (35)	2 (51)
EFV-375	3.5 (1588)	3.2 (1452)	3.71 (95)	2 (50)	1.75 (45)	1.5 (38)	1.38 (35)	2 (51)
EFV-500	4 (1814)	3.6 (1633)	4.46 (114)	2 (50)	1.75 (45)	1.75 (45)	1.38 (35)	2 (51)
EFV-750	4.8 (2177)	4.4 (1996)	5.35 (136)	2 (50)	1.75 (45)	2.13 (54)	1.38 (35)	2 (51)

How to Order

Sales@ChemTec.com | 800.222.2177

Model	Size	Materials	Manual Reset	Options
EFV	125 250 375 500 750	B Brass S 316SS (Other Material available on request)	MRS	ES* Reed Switch (Not available on 125 models) O2 Oxygen Cleaned HT High Temperature Unit 340°F (171°C) KZ FFKM Perfluoroelastomer EPR EPR Seals FP* Factory Presetting (State flow rate, medium and line pressure) Required W/ES Option ESFP Normally Open Reed Switch Option Requires Factory Presetting

*Consult Factory | Viton® - E.I. Dupont & Co | Teflon® - E.I. Dupont & Co | Kalrez® - E.I. Dupont & Co
All dimensions are subject to change for quality improvement. Not responsible for printing errors.

HPEFV Series

Adjustable High Pressure Safety Excess Flow Valve

Key Features

Controls high pressure excessive flows.

Features

- Controlled Bleed Resets Automatically
- Field Adjustable
- Positive Shut-off Option
- Materials: 316SS
- Maximum Pressure 6000 PSIG
- Detects Excess Flows
- Output: Switch Contact (Optional)
- Function: Restricts or Shuts Off Flow

Applications

- CNG Delivery
- High Pressure Plant Lines
- Hydraulic Systems



Operation

Flow enters the unit and makes a right angle to the outlet port across the nose of a magnetic piston. The piston is held in place by attraction to an adjusting screw magnet. A pressure differential is created by flow across the piston. When the differential is great enough, the piston slides to a seat at the outlet port. The flow rate at which the piston actuates can be changed externally by turning the adjusting screw, thereby changing the piston's relationship with the flow stream. In the auto reset model after actuation, the piston resets on a metal to metal seat that allows a controlled bleed. To reset the unit, pressure must be equalized on both sides of the piston.

For positive shut-off an elastomer is used on the nose of the piston. When it comes to rest on the seat it provides a bubble tight closure. To reopen the valve there are two options.

1. The upstream pipeline must be bled to atmosphere if the line downstream is at atmosphere.
2. A by-pass line with an on/off valve must be installed to port the upstream pressure to the down-stream pipeline to equalize the pressure.

- Actuation points for air at 68°F and 14.7 PSIA.

Correction must be made for other fluids, line pressure and temperatures. Please consult your representative or the factory.

Temperature Operating Range

- 32° to 220°F (-0° to 104°C)
For other temperature ranges consult factory.

Calibration Range

Model	Adjustable Range Air SLPM (SCFM)	Adjustable Range Water LPM (GPM)	PORT FNPT
HPEFV-250	4 to 1132 (0.14 to 40)	0.100 to 15.1 (0.026 to 4)	1/4"
HPEFV-500	142 to 2123 (5 to 75)	1.9 to 37.8 (0.5 to 10)	1/2"
HPEFV-750	425 to 3681 (15 to 130)	3.8 to 75.7 (1 to 20)	3/4"

Pressure Loss

Model	Air SLPM (SCFM)	Water LPM (GPM)	ΔP to Atmosphere BARD (PSID)
HPEFV-250	4 (0.14)	0.1 (0.26)	0.21 (3.0)
	500 (17.5)	5 (1.32)	0.41 (6)
	1132 (39.62)	15.1 (3.99)	0.83 (12)
HPEFV-500	142 (4.97)	1.9 (0.5)	0.07 (1)
	1000 (35)	25 (6.6)	0.28 (4)
	2123 (74.31)	37.8 (9.98)	0.48 (7)
HPEFV-750	425 (14.88)	3.8 (1)	0.14 (2)
	1800 (63)	4.7 (12.4)	0.21 (3)
	3681 (128.84)	75.7 (19.98)	0.34 (5)

HPEFV Series

Adjustable High Pressure Safety Excess Flow Valve

ES - Option

Switch Data	SPST UL File #E471070	LEADS
Maximum Switching Voltage		
DC (V)	250	
AC (V)	265	
Contact Rating		leads 18 in. min. from body 22 AWG, TFE insulation
DC (W)	50	
DC (VA)	50	
Maximum Switching Current (A)		
DC (A)	1.5	
AC (A)	1.1	

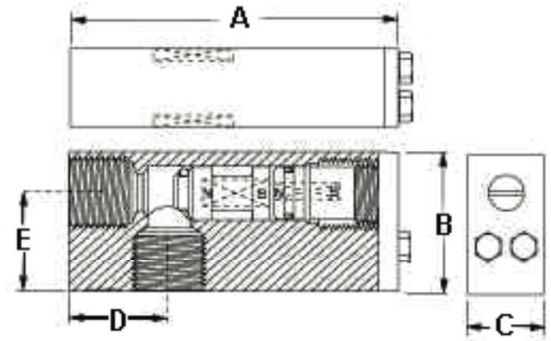

Specifications

Body Material	Max Working Pressure PSIG (barg)	Wetted Parts	Seal
316SS	6,000 (206.84)	316SS, Epoxy	Viton®

Installation

We suggest the unit be calibrated in the attitude in which it will be installed. An actuation point approximately 3 or 4 times the normal Maximum flow rate at the lowest line pressure should be chosen to avoid the valve actuating from initial pressurization of the system and normal surges. If flow is kept constant, an actuation point 10% above the normal rate may be used.

Dimensions

Model	Weight	A	B	C	D	E
HPEFV-250	1.47 (0.667)	3.75 (149)	1.5 (38)	1 (25)	1 (25)	1 (25)
HPEFV-500	2.625 (1.19)	4.25 (108)	2 (50)	1.25 (32)	1.25 (32)	1.37 (35)
HPEFV-750	3.44 (1.56)	5.25 (133)	2.25 (57)	1.25 (32)	1.625 (45)	1.625 (41)

How to Order

Sales@ChemTec.com | 800.222.2177

Model	Size	Materials	Positive Shut-Off	Options
HPEFV	200 500 750	S 316SS (Other Material available on request)	PSO (Blank for controlled bleed model)	O2 Oxygen Cleaned HT High Temperature Unit 340° F (171° C) KZ FFKM Perfluoroelastomer EPR EPR Seals FP* Factory Presetting (State flow rate, medium and line pressure) Required W/ES Option ESFP Normally Open Reed Switch Option Requires Factory Presetting

*Consult Factory | Viton® - E.I. Dupont & Co | Teflon® - E.I. Dupont & Co | Kalrez® - E.I. Dupont & Co
All dimensions are subject to change for quality improvement. Not responsible for printing errors.