

MAO Series

125/250 Flow Meter

Key Features

All Teflon® wetted parts model available. No seals. Undamaged by over ranging.

Features

- No Bearings
- Single Moving Part
- In Line Metering
- No Rotating Internals
- Materials: 316SS, Brass or Teflon®
- Output: Analog, Digital and Current loop
- Measures Low Flows

Applications

- Wet Benches
- Cooling Systems
- Corrosive Chemical Dispensing
- Materials Consumption Measurement
- Process Controls
- Patent No's 4,858,647 4,905,844 5,033,311
- Others may apply.



Operation

When fluid flows through the unit it displaces the Teflon encapsulated magnetic piston. This displacement is proportional to the volumetric flow through the unit. A transducer, encapsulated in the body outside the fluid path, senses the displacement of the piston. The transducer's signal is converted by a microprocessor-based conditioning circuit then sends the signal to three types of outputs: voltage, pulse and current loop.

- Total accuracy: ±5%
- Repeatability: ±2% full scale
- Linearity: ±2% full scale

Temperature Operating Range

- Ambient: 0° to 125°F (-18° to 52°C)
- Media: 0° to 180°F (-18° to 82°C)

Specifications			
Model	Weight Lbs. (Kg.)	Max Working Pressure PSIG (barg)	Wetted Parts
MAO-125/250-T	0.63 (0.29)	80 (5.51)	Teflon®
MAO-125/250-B	1.30 (0.59)	1500 (103.42)	Brass, Teflon®
MAO-125/250-S	1.30 (0.59)	3000 (206.84)	316SS, Teflon®

Pressure Loss			
Model	Min/Max	Linear Range ML/M (GPH)	ΔP MBARS (PSID)
MAO-125-AA	Minimum	20 (0.32)	24.82 (0.36)
	Maximum	70 (1.11)	42.06 (0.61)
MAO-125-BB	Minimum	50 (0.79)	8.27 (0.12)
	Maximum	150 (0.79)	10.34 (0.15)
MAO-250-AA	Minimum	100 (1.59)	8.27 (0.12)
	Maximum	500 (7.93)	9.65 (0.14)
MAO-250-BB	Minimum	260 (4.12)	10.34 (0.15)
	Maximum	1800 (28.54)	20 (0.29)

Calibration in Water

Model	ML/MIN (GPH)	VDC	Hz	mA	Ports FNPT
MAO-125XAA	0	0	0	0	1/8"
	20 (0.317)	1	40	4	
	32.5 (0.5151)	2	80	8	
	45 (0.7133)	3	120	12	
	57.5 (0.9114)	4	160	16	
MAO-125XBB	70 (1.1095)	5	200	20	1/8"
	0	0	0	0	
	50 (0.7925)	1	40	4	
	75 (1.1888)	2	80	8	
	100 (1.585)	3	120	12	
MAO-250XAA	125 (1.9813)	4	160	16	1/4"
	150 (2.3775)	5	200	20	
	0	0	0	0	
	100 (1.585)	1	40	4	
	200 (3.1701)	2	80	8	
MAO-250XBB	300 (4.7551)	3	120	12	1/4"
	400 (6.3401)	4	160	16	
	500 (7.9252)	5	200	20	
MAO-250XBB	0	0	0	0	1/4"
	250 (3.9626)	1	40	4	
	638 (10.1125)	2	80	8	
	1025 (16.2466)	3	120	12	
	1413 (22.3965)	4	160	16	
1800 (28.5306)	5	200	20		

CE

*Users are solely accountable for product selection, regardless of any recommendations or suggestions provided by ChemTec Equipment Company, Inc. Users should base product selection on their own analysis and testing to determine functionality and material compatibility in relation to their application. To ensure safe and trouble-free performance, it is essential to adhere to proper installation, operation, and maintenance procedures.

Electrical Specifications

POWER REQUIREMENTS:

Voltage: Regulated 15 – 30 VDC
 Current: 250 mA

OUTPUTS:

ANALOG: 0 – 5 VDC
 Minimum Load Impedance: 5k ohm in parallel with 250pf

DIGITAL:

200 Hz, Square wave 50% duty cycle TTL compatible output.

CURRENT LOOP:

Current Loop: 4 - 20 mA
 Loop Load : 100Ω ±1% 1/4 watt

WIRE CONNECTION:

- Red – (+)
- Black – (Common)
- White – (Frequency)
- Green – (Voltage)
- Brown – (Current)

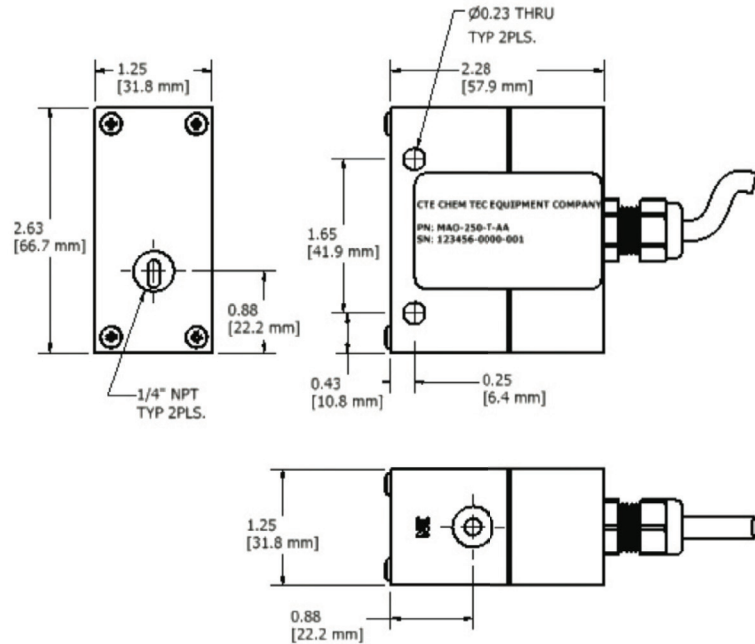

How to Order

Sales@ChemTec.com | 800.222.2177

Model	Size	Switch	Options
MAO	125	T	(See Chart)
	250	B	AA
		S	BB

*Consult Factory **Standard with Teflon unit | Viton® - E.I. Dupont & Co | Teflon® - E.I. Dupont & Co | Kalrez® - E.I. Dupont & Co
 All dimensions are subject to change for quality improvement. Not responsible for printing errors.

Installation

Control valves should be placed downstream of the MAO flow meter. The flow meter should never be installed so that it drains completely when flow ceases. When particles may be present in the media, a filter should be installed ahead of the flow meter. It is advisable to filter to 10 microns. The MAO flow meter should not be located near ferrous material or near strong electro-magnetic fields.

The MAO flow meter is sensitive to velocity profile disturbances in the flow stream. It is advisable that straight lengths of 10 inside diameters upstream and 5 inside diameters downstream be used. All lines should be completely purged of air before use. The use of pipe paste is not recommended. Use care when using Teflon tape to avoid shreds from entering the MAO flow meter.

Mounting

Mount with INLET vertical, port facing down. OUTLET port horizontal.

*Users are solely accountable for product selection, regardless of any recommendations or suggestions provided by ChemTec Equipment Company, Inc. Users should base product selection on their own analysis and testing to determine functionality and material compatibility in relation to their application. To ensure safe and trouble-free performance, it is essential to adhere to proper installation, operation, and maintenance procedures.