

FAV Series

Adjustable Flow Monitor

15

Key Features

Best for applications where the normal flow to set point is 10:1 or greater.

Features

- Adjustable Flow Monitor
- Monitors both Gases and Liquids
- Materials: Brass or 316SS
- Confirms: Normal Flow Conditions
- Senses: High Flow or Low Flow Conditions
- Output: Switch Contact

Operation

When flow is increased, the magnetic piston is forced against a bias spring. As the magnet comes near the adjustable reed switch it actuates, indicating proper flow. When flow decreases the spring forces the piston in the opposite direction deactuating the reed switch and indicating a reduce or no flow condition. The magnetic piston actuates a hermetically sealed reed switch, which is encapsulated in the body of the unit, out of the air/water path.

- Actuation points for air at 68 F and 14.7 PSIA with increasing flow.
- Deactuation (decreasing flow) averages 40% less than actuation (increasing flow)
- Repeatability $\pm 2\%$
- Unit will pass greater flows

Correction must be made for other fluids, line pressure and temperatures. Please consult your representative or the factory.

Applications

- Process Controls
- Fire Control Systems
- Water Treatment Chemicals
- Cooling Systems
- Heat Pumps
- Hydraulic Lifts
- Industrial Analyzers
- Plant Safety

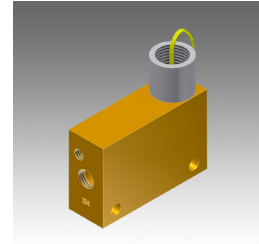

Calibration Range

Model	Air SLPM (SCFM)	Water LPM (GPM)	Inlet/Outlet FNPT Port Inches
FAV-250			1/4"
Minimum	14.16 (0.5)	0.38 (0.10)	
Maximum	1416 (50)	15.14 (4)	
FAV-375			3/8"
Minimum	14.16 (0.5)	0.38 (0.10)	
Maximum	1416 (50)	15.14 (4)	
FAV-500			1/2"
Minimum	28.32 (1)	1.89 (0.5)	
Maximum	2124 (75)	37.85 (10)	
FAV-750			3/4"
Minimum	141.6 (5)	3.78 (1)	
Maximum	3398 (120)	75.7 (20)	

Specifications

Model	Weight Lbs (kg)	Max Working Pressure PSIG (barg)	Wetted Parts
FAV-250-B	1.4 (0.635)	1500 (103.42)	Brass, Epoxy, 316SS
FAV-250-S	1.4 (0.635)	3000 (206.84)	316SS, Epoxy
FAV-375-B	1.4 (0.635)	1500 (103.42)	Brass, Epoxy, 316SS
FAV-375-S	1.4 (0.635)	3000 (206.84)	316SS, Epoxy
FAV-500-B	1.4 (0.635)	1500 (103.42)	Brass, Epoxy, 316SS
FAV-500-S	1.7 (0.635)	3000 (206.84)	316SS, Epoxy
FAV-750-B	1.7 (0.771)	1500 (103.42)	Brass, Epoxy, 316SS
FAV-750-S	1.7 (0.771)	3000 (206.84)	316SS, Epoxy

Pressure Loss

Model	Air Flow Rate SLPM (SCFM)	Water Flowrate LPM (GPM)	ΔP to Atmosphere BARD (PSID)
FAV-250/375			
Minimum	14.2 (0.5)	0.38 (0.10)	0.34 (0.5)
Maximum	1416 (50)	15.14 (4)	0.21 (3)
FAV-500			
Minimum	28.32 (1)	1.89 (0.5)	0.069 (1)
Maximum	2124 (75)	37.85 (10)	0.689 (10)
FAV-750			
Minimum	141.6 (5)	3.78 (1)	0.10 (1.5)
Maximum	3398 (120)	75.7 (20)	0.62 (9)

Temperature Operating Range

- 0° to 220°F (-17° to 104°C) for Brass and Stainless Steel
- For other temperature ranges consult factory.



**Users are solely accountable for product selection, regardless of any recommendations or suggestions provided by ChemTec Equipment Company, Inc. Users should base product selection on their own analysis and testing to determine functionality and material compatibility in relation to their application. To ensure safe and trouble-free performance, it is essential to adhere to proper installation, operation, and maintenance procedures.*

FAV Series

Adjustable Flow Monitor

16

Switch Data	SPST	SPDT
Maximum Switching Voltage		
DC (V)	250	175
AC (V)	265	120
Contact Rating		
DC (W)	50	5
AC (VA)	50	5
Maximum Switching Current (A)		
DC (A)	1.5	0.25
AC (A)	1.1	0.18

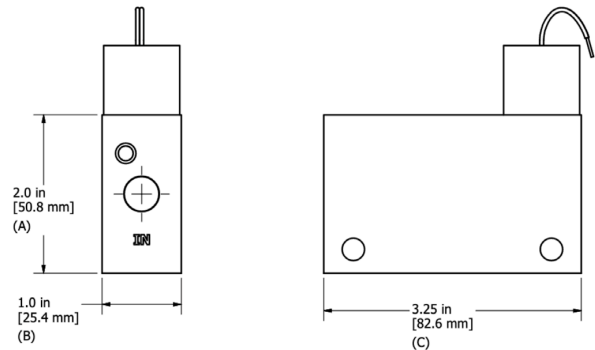

Leads	SPST UL File #E471070	SPDT UL File #E471070
<p>leads 18 in. min. from body 22 AWG, TFE insulation</p>	<p>leads 18 in. min. from body 24 AWG, TFE insulation</p> <ul style="list-style-type: none"> • green - N.C. • blue - N.O. • white - Common 	

Installation

Mount with the inlet port on the side horizontally. Other attitudes change the adjustable range of the unit. A 100 micron filter is recommended.

Dimensions

Model	A	B (Metal)	B (Plastic)	C
FAV-250	2.0 (50.8)	1.00 (25.4)	1.25 (31.75)	3.25 (82.6)
FAV-375	2.0 (50.8)	1.00 (25.4)	1.25 (31.75)	3.25 (82.6)
FAV-500	2.0 (50.8)	1.00 (25.4)	1.375 (34.925)	3.25 (82.6)
FAV-750	2.75 (69.9)	1.25 (31.8)	1.50 (38.1)	4.25 (108)

How to Order

Sales@ChemTec.com | 800.222.2177

Model	Materials	Type of Service	Switch	Options
FAV 250 375 500 750	B Brass S 316SS	W Water G Gas	N.O. Normally Open SPDT Single Pole Double Throw	HT High Temperature Options 340 ° F (171°C) FP* Factory Preset

*Consult Factory | Viton® - E.I. Dupont & Co | Teflon® - E.I. Dupont & Co | Kalrez® - E.I. Dupont & Co
All dimensions are subject to change for quality improvement. Not responsible for printing errors.

*Users are solely accountable for product selection, regardless of any recommendations or suggestions provided by ChemTec Equipment Company, Inc. Users should base product selection on their own analysis and testing to determine functionality and material compatibility in relation to their application. To ensure safe and trouble-free performance, it is essential to adhere to proper installation, operation, and maintenance procedures.