

# EFV MRS Series

Manual Reset Adjustable Excess Flow Valve

## Key Features

Controls excessive flows.

## Features

- Field Adjustable
- Manual Reset
- Materials: 316SS
- Detects Excess Flows
- Function: Shuts Off Flow
- Output: Switch Contact (Optional)

## Applications

- Plant Lines
- Regulator Failure
- Fitting Failure
- Toxic Gases & Liquids
- Gas Distribution Systems
- Gas Analyzers
- Loss Controls



## Operation

Flow enters the unit and makes a right angle to the outlet port across the nose of a magnetic piston. The piston is held in place by attraction to an adjusting screw magnet. A pressure differential is created by flow across the piston. When the differential is great enough, the piston slides to a seat at the outlet port. The flow rate at which the piston actuates can be changed by turning the adjusting screw, thereby changing the piston's relationship with the flow stream. The piston makes a bubble tight seal when it comes in contact with the seat. To reopen the unit, turn the balancing valve handle on the side. This ports the upstream pipeline to the downstream pipeline. When the pressure is equalized on each side of the piston, it will reset. The unit is returned to normal operation by closing the balancing valve.

- Actuation points for air at 68° F and 14.7 PSIA.

Corrections must be used for other gases, line pressure and temperatures.\* Please consult your representative or the factory.

## Temperature Range

- AMBIENT: 0° to 125°F (-18° to 52° C)
- MEDIA: 0° to 180°F (-18° to 82° C)

For other temperature ranges, consult the factory.



## Calibration Range

Model	Adjustable Range Air SLPM (SCFM)	Adjustable Range Water LPM (GPM)	PORT FNPT
EFV-125	0.5 to 155.7 (0.018 to 5.5)	0.015 to 4.5 (0.004 to 1.2)	1/8"
EFV-250	4 to 1132 (0.14 to 40)	0.100 to 15.1 (0.026 to 4.0)	1/4"
EFV-375	85 to 1840 (3.0 to 65)	0.380 to 15.1 (0.100 to 4.0)	3/8"
EFV-500	142 to 2123 (5.0 to 75)	1.90 to 37.8 (0.50 to 10.0)	1/2"
EFV-750	425 to 3681 (15.0 to 130)	3.80 to 75.7 (1.0 to 20.0)	3/4"

## Pressure Loss

Model	Air SLPM (SCFM)	Water LPM (GPM)	ΔP to Atmosphere BARD (PSID)
EFV-125	0.50 (0.018)	0.015 (0.004)	0.08 (1.2)
	75 (2.63)	2.65 (0.70)	0.11 (1.6)
	155 (5.5)	4.50 (1.20)	0.21 (3.0)
EFV-250	4 (0.14)	0.1 (0.26)	0.21 (3.0)
	500 (17.50)	5.0 (1.32)	0.41 (6.0)
	1132 (39.62)	15.1 (3.99)	0.83 (12.0)
EFV-375	85 (2.98)	0.38 (0.10)	0.10 (1.5)
	900 (31.50)	10.0 (2.64)	0.28 (4.0)
	1840 (64.40)	15.1 (3.99)	0.83 (12.0)
EFV-500	142 (4.97)	1.9 (0.50)	0.07 (1.0)
	1000 (35.00)	25.0 (6.60)	0.28 (4.0)
	2123 (74.31)	37.8 (9.98)	0.48 (7.0)
EFV-750	425 (14.88)	3.8 (1.00)	0.14 (2.0)
	1800 (63.00)	4.7 (1.24)	0.21 (3.0)
	3681 (128.84)	75.7 (19.98)	0.34 (5.0)

\*Users are solely accountable for product selection, regardless of any recommendations or suggestions provided by ChemTec Equipment Company, Inc. Users should base product selection on their own analysis and testing to determine functionality and material compatibility in relation to their application. To ensure safe and trouble-free performance, it is essential to adhere to proper installation, operation, and maintenance procedures.

# EFV MRS Series

Manual Reset Adjustable Excess Flow Valve

ES - Options		
Switch Data	SPST UL File #E471070	LEADS
Maximum Switching Voltage		
DC (V)	250	
AC (V)	265	
Contact Rating		leads 18 in. min. from body 22 AWG, TFE insulation
DC (W)	50	
DC (VA)	50	
Maximum Switching Current (A)		
DC (A)	1.5	
AC (A)	1.1	

Body Material	Max Working Pressure PSIG (barg)	Wetted Parts	Seals
Brass	1500 (103.42)	Brass, Epoxy, Delrin (Brass Piston in 125 Unit)	Viton®
316SS	3000 (206.84)	316SS, Epoxy	Viton®

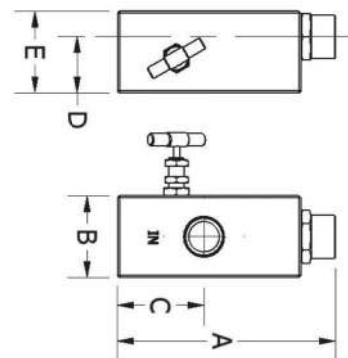

## Installation

We suggest the unit be calibrated in the attitude in which it will be installed. An actuation point approximately 3 or 4 times the normal Maximum flow rate at the lowest line pressure should be chosen to avoid the valve actuating from initial pressurization of the system and normal surges. If flow is kept constant, an actuation point 10% above the normal rate may be used.

Dimensions								
Model	316SS Weight (lbs/gm)	Brass Weight (lbs/gm)	A	B 316SS	B Brass	C	D	E
EFV-125	1.5 (680)	1.6 (726)	2.72 (69)	1.5 (38)	1.5 (38)	0.95 (24)	1.12 (28)	1.62 (41)
EFV-250	3.5 (1588)	3.3 (1497)	3.71 (95)	2 (50)	1.75 (45)	1.5 (38)	1.38 (35)	2 (51)
EFV-375	3.5 (1588)	3.2 (1452)	3.71 (95)	2 (50)	1.75 (45)	1.5 (38)	1.38 (35)	2 (51)
EFV-500	4 (1814)	3.6 (1633)	4.46 (114)	2 (50)	1.75 (45)	1.75 (45)	1.38 (35)	2 (51)
EFV-750	4.8 (2177)	4.4 (1996)	5.35 (136)	2 (50)	1.75 (45)	2.13 (54)	1.38 (35)	2 (51)

## How to Order

Sales@ChemTec.com | 800.222.2177

Model	Size	Materials	Manual Reset	Options
EFV	125 250 375 500 750	B Brass S 316SS  (Other Material available on request)	MRS	ES* Reed Switch (Not available on 125 models) O2 Oxygen Cleaned HT High Temperature Unit 340°F (171°C) KZ FFKM Perfluoroelastomer EPR EPR Seals FP 3X Max Flow (SLPM) / Gas / Line Pressure (PSIG) ESFP Normally Open Reed Switch Option Requires Factory Presetting

\*Consult Factory | Viton® - E.I. Dupont & Co | Teflon® - E.I. Dupont & Co | Kalrez® - E.I. Dupont & Co  
All dimensions are subject to change for quality improvement. Not responsible for printing errors.

\*Users are solely accountable for product selection, regardless of any recommendations or suggestions provided by ChemTec Equipment Company, Inc. Users should base product selection on their own analysis and testing to determine functionality and material compatibility in relation to their application. To ensure safe and trouble-free performance, it is essential to adhere to proper installation, operation, and maintenance procedures.